



ITE
cLAMPs

CC5516 Light Cable Clamps

Lightweight versions of CC5516 legacy



Commercial Aerospace

Defence

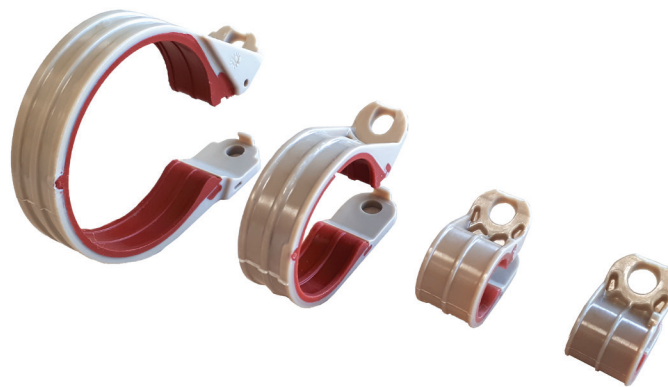

BROCHURE 04/19 - V1.0



Amphenol Air LB

Your Satisfaction. Everyday. Everywhere.

PRESENTATION

CC5516 Light series is the Lightweight version of the CC5516 standard Cable Clamps series.

The weight saving compared to the metallic version is important.

**WEIGHT SAVING
UP TO 24% !**

They are designed to keep the cable harnesses or hydraulic pipes securely maintained on structure.

They have an integrated prelocking system which allows to preposition the clamp on the harness.

The screw (not supplied) allows to lock the clamp and fix it on structure in one operation

**WEIGHT SAVING
UP TO 73% !**

TIME SAVING

CC5516 Light clamps absorb shocks and vibrations, and offer an unequalled protection of bundles and pipes against pinching, crushing or mechanical wear.

RELIABILITY

They are suited for applications in harsh environment and temperatures up to 225°C.

HIGH TEMPERATURE

Thanks to their design, it is possible to stack them whatever their size.

They are available in 10 sizes, for bundles or pipes diameters from 5 to 25,4 mm.

APPLICATIONS IN HARSH ENVIRONMENTS

Commercial Aerospace & Defence

STANDARDS AND QUALIFICATIONS

RTCA DO 160G (products)

ABS1916 (tests)

REACH AND ROHS

In accordance with the REACH spec.

In accordance with the RoHS spec.

CLAMP RANGE

10 sizes available

Size	04	06	08	10	12	14	18	21	22	29
Bundle / Pipe diameter	5	6,3	8	9,5	11	12,7	15,9	18	19	25,4

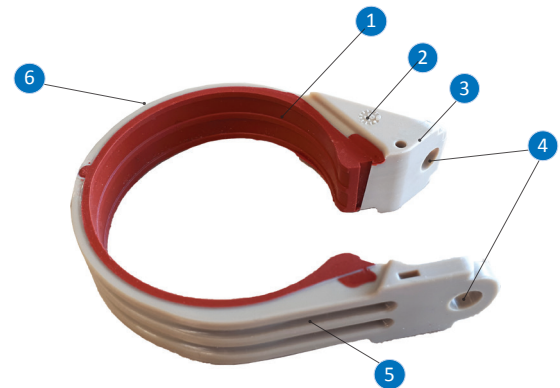

CAPTION

- 1 - Silicone cushion
- 2 - Date code
- 3 - Clamp band
- 4 - Fixing \varnothing 5,2 mm
- 5 - CC5516 Light P/N engraved
- 6 - Clamp size engraved

MAIN TECHNICAL FEATURES

MATERIAL

Clamp band : Thermoplastic
Cushion : Silicone elastomer

ENVIRONMENTAL

Operating temperature : -55° to +225°C permanent

ELECTRICAL (as per ABS1916 standard)

Insulation resistance : > 10⁶ M Ω

FLAMMABILITY / SMOKE / TOXICITY

ABD 0031
FAR 25.853

FLUIDS RESISTANCE (as per RTCA DO 160G standard)

Spray tests: fuels, hydraulic fluids, lubrication oils, solvent and cleaning fluids, de-icing fluids, insecticides

MECHANICAL (as per RTCA DO 160G standard)

Shocks : 6g during 20 ms
Vibrations : 3 H per axis, resonance frequency > 30 Hz
Windmilling test : 6g, frequency 2,9 to 30 Hz
Load test : depending on the clamp size, in 4 directions
Nose wheel imbalance : 3,5 to 10g, frequency 5 to 27 Hz

MOUNTING (as per RTCA DO 160G standard)

Closure and fixing : Screw / washer \varnothing 5,2 mm
Screw (recommended) : .1900-32UNJF or NSA5191-3
Washer (recommended) : NAS1149D0332J
Tightening torque : 4,2 Nm
Clamp opening : 90° maximum recommended

WEIGHTS

Size	04	06	08	10	12	14	18	21	22	29
Weight of CC5516 Light clamps (g)	1,40	1,55	1,75	1,95	2,25	2,55	3,15	3,45	3,65	4,90
Weight of CC5516 standard clamps (g)	1,80	2,05	2,25	2,50	2,70	3,00	3,90	4,20	4,35	5,50
Weight of metallic clamps (g)	4,60	5,50	6,30	7,10	7,80	8,90	10,60	11,90	12,40	15,50
Weight saved versions Light / standard	-22%	-24%	-22%	-22%	-17%	-15%	-19%	-18%	-16%	-11%
Weight saved versions Light / metallic	-70%	-72%	-72%	-73%	-71%	-71%	-70%	-71%	-71%	-68%

PART NUMBERS & DIMENSIONS

TECHNICAL DRAWINGS

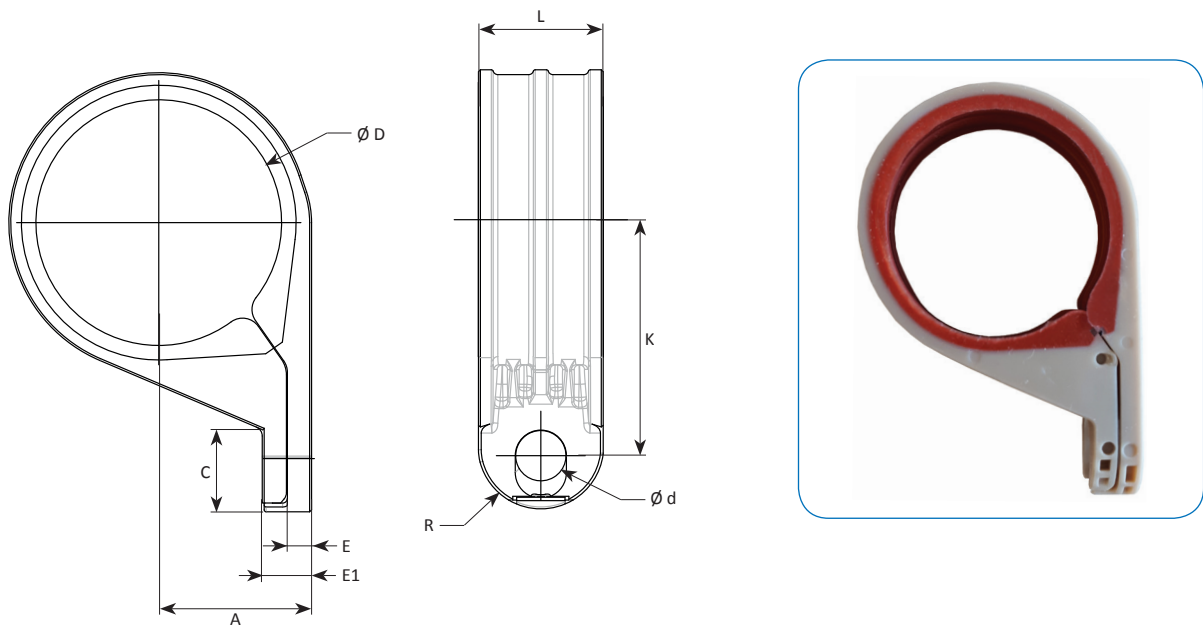

PART NUMBERS AND DIMENSIONS

Part Number CC5516 Light	Clamp size	Bundle / Pipe diameter ØD (mm)	A		K		C	E	E1	R	L	Ød
			mm	tolerance	mm	tolerance						
CC5516B04L	04	5	5,8	± 0,3	12,6	± 0,5	8,5	2	2	6,35 ± 0,2	13,1 maxi	5,2
CC5516B06L	06	6,3	6,6	13,4								
CC5516B08L	08	8	7,3	14,1								
CC5516B10L	10	9,5	8,1	14,9								
CC5516B12L	12	11	8,8	15,6								
CC5516B14L	14	12,7	9,8	16,6								
CC5516B18L	18	15,9	11,3	19,9	2,5			2,5				
CC5516B21L	21	18	12,3	20,9								
CC5516B22L	22	19	12,8	21,3								
CC5516B29L	29	25,4	15,8	24,4								

IMPLEMENTATION

RECOMMENDATIONS

Regarding the insertion of cable bundles or hydraulic pipes inside the CC5516 Light cable clamps, Amphenol Air LB France recommend a maximum opening angle of 90°. When stacking multiple clamps, the maximum angle of inclination is 30°.

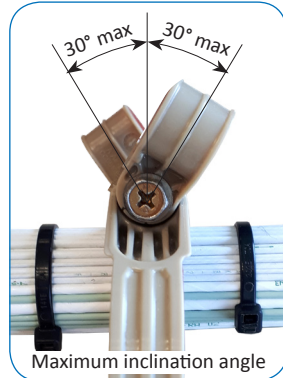
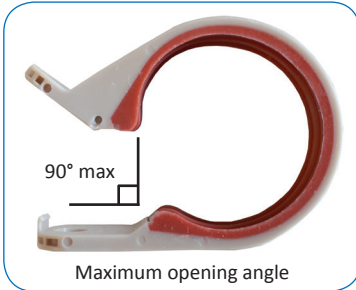

CC5516 Light clamps are closed and fixed on structure, in one operation, using a screw and a washer (not supplied) matching the diameter of the fixing hole (5,2 mm). Amphenol Air LB France recommend to use the following hardware:

- Screw: .1900-32UNJF or NSA5191-3
- Washer: NAS1149D0332J

Tightening torque recommended: 4,2 Nm

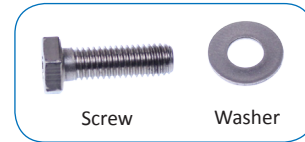

IMPLEMENTATION INSTRUCTIONS

Mounting:

- 1 Prepositioning of clamps on cable bundles and prelocking. Even prelocked, it is possible to adjust the position of clamps by sliding along the bundle.
- 2 Locking and fixing on structure with screw and washer in one operation.

