



# CC1339 Light Clamps

Lightweight Cable Clamps



Commercial Aerospace  
Defence



BROCHURE 12/18 - V4.0



# Amphenol Air LB

Your Satisfaction. Everyday. Everywhere.

# PRESENTATION

CC1339 Light series is a new line of lightweight monoblock Cable Clamps, in composite and silicone.

They are designed to keep the cable harnesses securely maintained on structure. They are fixed on structure by a screw and a washer (not supplied) and closed with a standard cable-tie (not supplied) of 5,5 mm width maximum.

Robust and flexible, CC1339 Light clamps absorb shocks, vibrations, and offer an unequalled protection of bundles against pinching, crushing or mechanical wear, thanks to a silicone cushion.

They are suited for applications in standard environment (general use) and temperatures up to 150°C.

They are available in 8 sizes, for bundles diameters from 5 to 48 mm.

## APPLICATIONS IN HARSH ENVIRONMENTS

Commercial Aerospace & Defence

## STANDARDS AND QUALIFICATIONS

RTCA DO 160G (products)  
ABS1916 and ABS1337 (tests)

## REACH AND ROHS

In accordance with the REACH spec.  
In accordance with the RoHS spec.

## CLAMP RANGE

8 sizes available

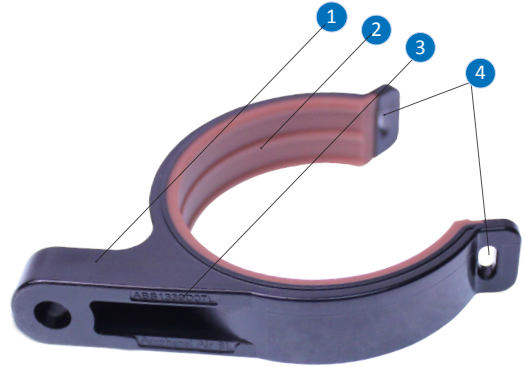

### CAPTION

- 1 - Clamp Band
- 2 - Silicone Cushion
- 3 - CC1339Light P/N engraved
- 4 - Fixing by cable-Tie 5,5 mm width max.

Size	01	02	03	04	05	06	07	08
Bundle diameter (mm)	5 to 8	8 to 11	10,5 to 14	13,5 to 19,5	19 to 26	25,5 to 33	32,5 to 40	39,5 to 48

# MAIN TECHNICAL FEATURES

## MATERIAL

Clamp Band : Thermoplastic  
Cushion : Silicone elastomer

## ENVIRONMENTAL

Operating Temperature : -55° to +150°C permanent

## ELECTRICAL

Insulation resistance : > 10<sup>6</sup> MΩ

## FLAMMABILITY / SMOKE / TOXICITY

ABD 0031  
FAR 25.853

## WEIGHTS

Size	01	02	03	04	05	06	07	08
Weight of CC1339 Light clamps (g)	1,75	2,15	2,65	3,3	4,35	6,8	9,5	12,5

## FLUIDS RESISTANCE

: as per RTCA DO 160G standard  
Spray tests : Fuels, Hydraulic fluids, Lubrication Oils, Solvent and Cleaning fluids, De-icing fluids, insecticides

## MECHANICAL

: as per RTCA DO 160G standard  
Shocks : 6g during 20 ms  
Vibrations : 3 H per axis, resonance frequency > 30 Hz  
Windmilling test : 6g, frequency 2,9 to 30 Hz  
Load test : depending on the clamp size, in 4 directions  
Nose wheel imbalance : 3,5 to 10g, frequency 5 to 27 Hz

## MOUNTING

: as per RTCA DO 160G standard  
Closure and Fixing : Screw / washer Ø 5,2 mm  
Screw / washer (recommended) : NAS1801-03 / NAS1149  
Tightening torque : 3,2 Nm (+/- 0,5 Nm)  
Clamp closure : Cable-tie (5,5 mm width)  
Cable-tie (recommended) : NSA 935401-05

# PART NUMBERS & DIMENSIONS

## ■ PART NUMBERING SYSTEM

CC1339 D **01** L

Clamp size: 01 to 08 ————

Lightweight version: L ————



## ■ TECHNICAL DRAWINGS

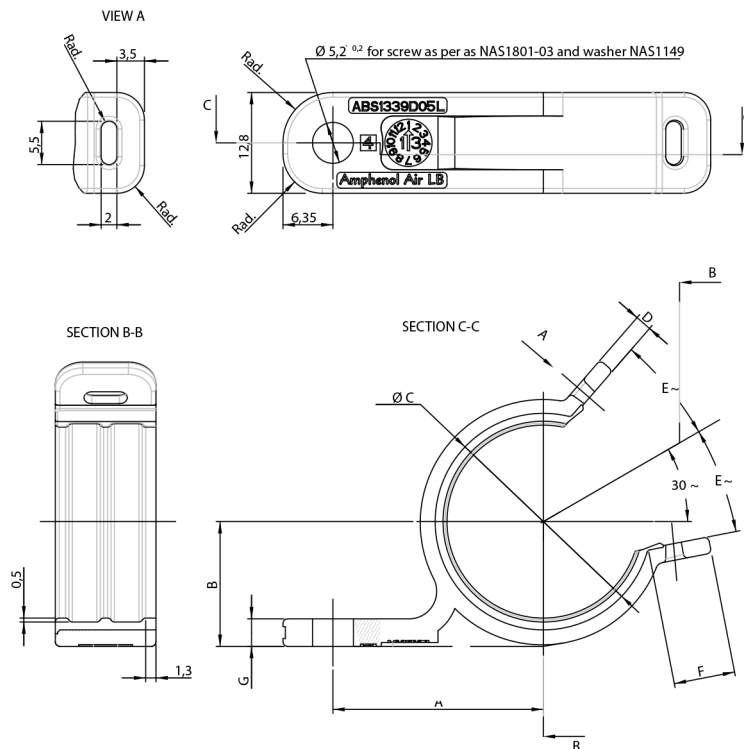

## ■ DIMENSIONS

Part Number CC1339Light	Clamp size	Admissible Bundle diameters (mm)	A (mm)	B (mm)	ØC (mm)	D (mm)	E (°)	F (mm)	G (mm)
CC1339 D 01 L	01	5 to 8	17	5,5	8	1,7	15	7,4	3,5
CC1339 D 02 L	02	8 to 11	18,5	7,15	11	1,8	16	7,5	
CC1339 D 03 L	03	10,5 to 14	20,4	9,2	14,8	1,9	17	7,6	
CC1339 D 04 L	04	13,5 to 19,5	23,05	12	20,1	2	18	7,7	
CC1339 D 05 L	05	19 to 26	26,75	15,85	27,5	2,1	19	7,8	5,8
CC1339 D 06 L	06	25,5 to 33	31	20,25	36	2,5	20	7,9	
CC1339 D 07 L	07	32,5 to 40	36	25,4	46	2,8	21	8	8,3
CC1339 D 08 L	08	39,5 to 48	40	31	55				

# IMPLEMENTATION

Fixing and closure of CC1339 Light clamps are completed in 2 steps.

Pre-mounting on structure is possible. Once clamps are mounted on structure and cable harnesses put in, then CC1339 clamps can be closed.

## ■ CLAMPS FIXING

CC1339 Light clamps are fixed on structure, using a screw and a washer (not supplied) matching the diameter of the fixing hole (5,2 mm). Amphenol Air LB France recommend to use the following hardware :

- Screw : NAS1801-03
- Washer : NAS1149

Tightening torque : 3,2 Nm (nominal)



## ■ BUNDLE INSERTION & CLAMP CLOSING

Elastic properties of materials provide an easy insertion of Cable harnesses in the CC1339 Light Clamps.

They are closed with a cable-tie (5,5 mm width maximum). Amphenol Air LB France recommend to use a cable-tie as per NSA935401-05 standard.

Amphenol Air LB France recommend to use a cable-tie tool, as per MS 90387-1 (position 6 to 8), to provide the required tightening torque (about 120 N).

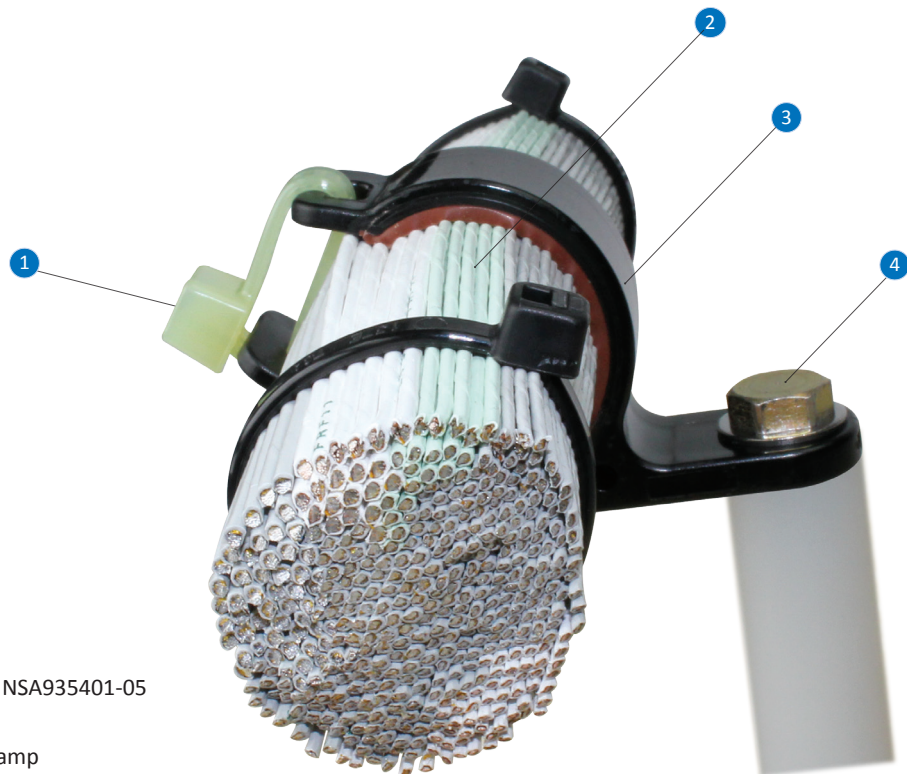

### **CAPTION**

- ① - Cable-tie as per NSA935401-05
- ② - Bundle
- ③ - CC1339 Light Clamp
- ④ - Screw NAS1801-03 + Washer NAS1149