

1084 Series - 110VDC LED 2D LAMP



Product Overview

- › Rolling Stock Compliant.
- › Replaces 28W 2D Fluorescent lamp.
- › High reliability LED and driver technology.
- › Built in drive electronics for direct connection to power source.
- › Significant energy savings.
- › Zero maintenance costs.
- › Flicker free lighting with instant start.
- › No mercury content, environmentally friendly.



Safety Specification

The 1084 Series comes equipped with the following protection circuitry:

- › DC input voltage reversal (Non destructive).
- › Input transient protection.
- › Under voltage protection.
- › Built in multiple LED circuit redundancy.
- › Protected against power supply interruptions (EN50155 Class S2 and C2)

Product Codes

	Warm	Natural	Cool
110VDC LED 2D LAMP 14W	TBA	10841000	TBA



Technical Overview

Size	190x190x32mm	
Input Voltage Range	67 - 140VDC	
Input Current at Nominal Supply	0.114mA \pm 5%	
Input Power at Nominal Supply	12.5W	
Line Regulation (Percentage Illuminance change oversupply range 67 - 140VDC)	\pm 5%	
Colour Temperature	Warm White	3000K \pm 5%
	Natural White	4000K \pm 5%
	Cool White	6000K \pm 5%
CRI	>80	
Beam Angle	200°	
Operating Temperature Range	-25 to 55°C	
Storage Temperature Range	-25 to 55°C	
Operating Humidity Range	10%-80%	
Lumen Maintenance (time to 70% of the initial light output)	50,000 hours	
MTBF MIL-HDBK-217F (40°C) (hrs)	100,000 hours	
Designed Service Life	15 years	
Sealing Rating	IP40	
Switch Cycles	>100,000 (UIC555)	
Connector/Lamp holder	GR10Q	
Weight	166g	



Mechanical Details

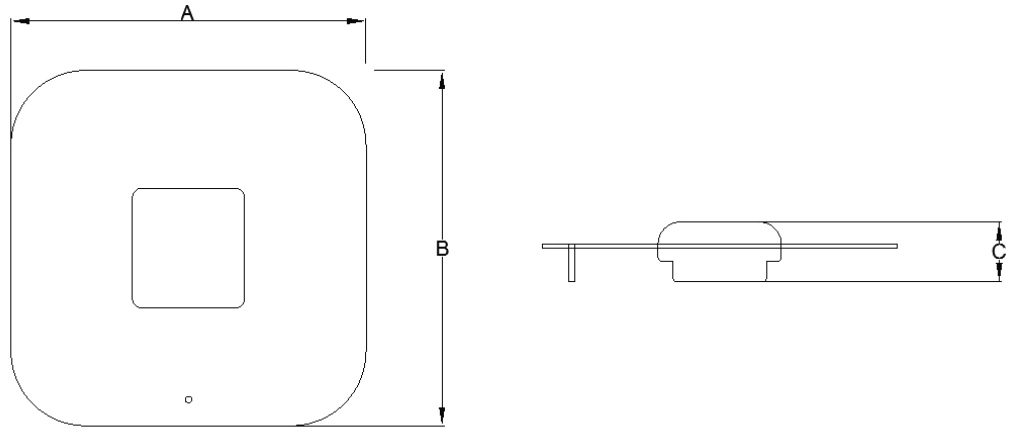

Unit Dimensions		
A	B	C
190mm	190mm	32mm

Photometric Data

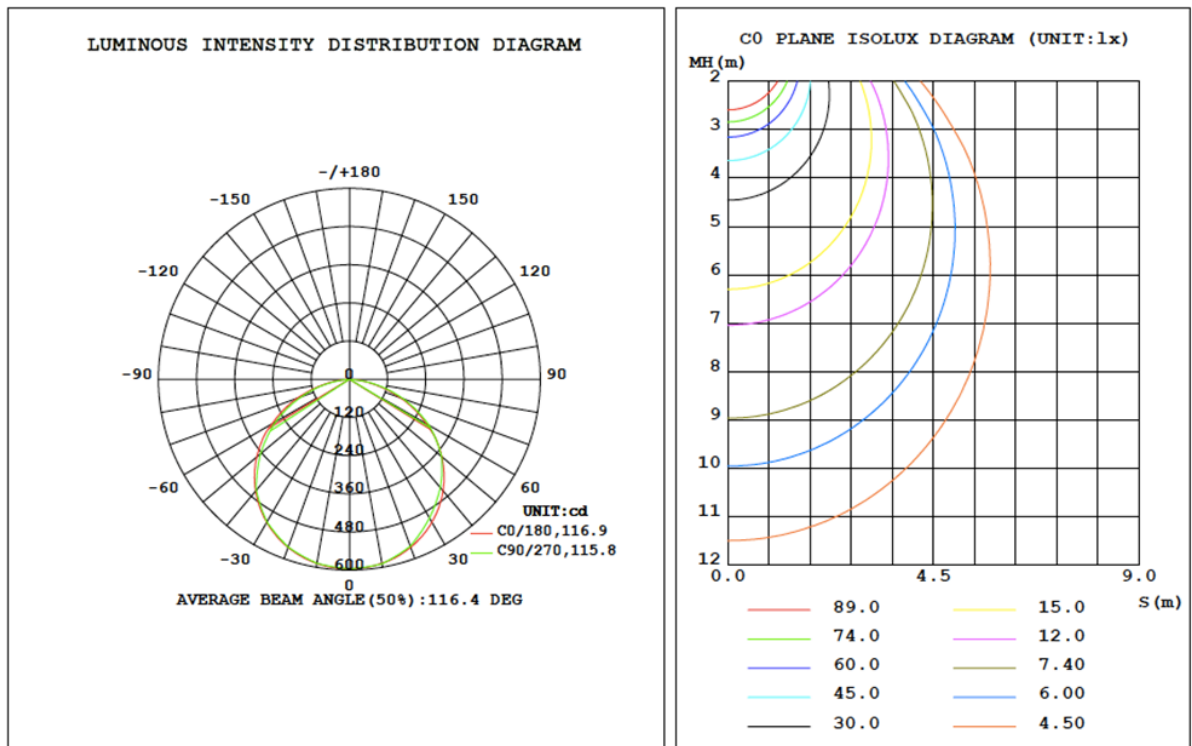

Size	Output (Lumens)
190x190x32mm	1800lm



Installation Guide

Mounts using existing 2D lamp holders.

Remove original fitment lighting ballast and replace it with 110VDC LED 2D LAMP.

Unit will operate correctly in either polarity.

In addition to the standard 2D lamp holder, a secondary mounting point with appropriate spacer (length dependent on the specific distance from lamp panel to the mounting base) must be used to securely install the 2D LED lamp.

ORIGINAL LAMP CONNECTION DETAILS

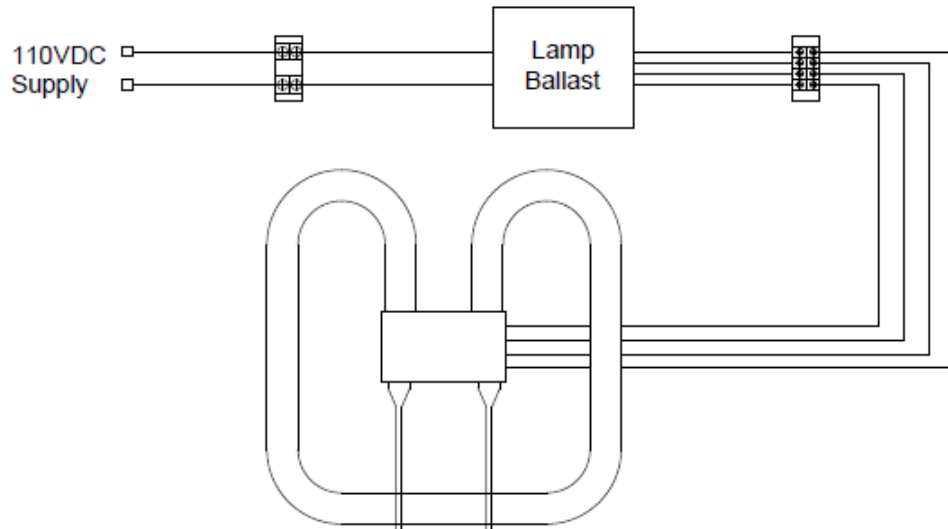

LED REPLACEMENT LAMP CONNECTION DETAILS

Ballast removed.
Supply linked over to lamp wiring.
Spacer fitted.
DC input voltage reversal.

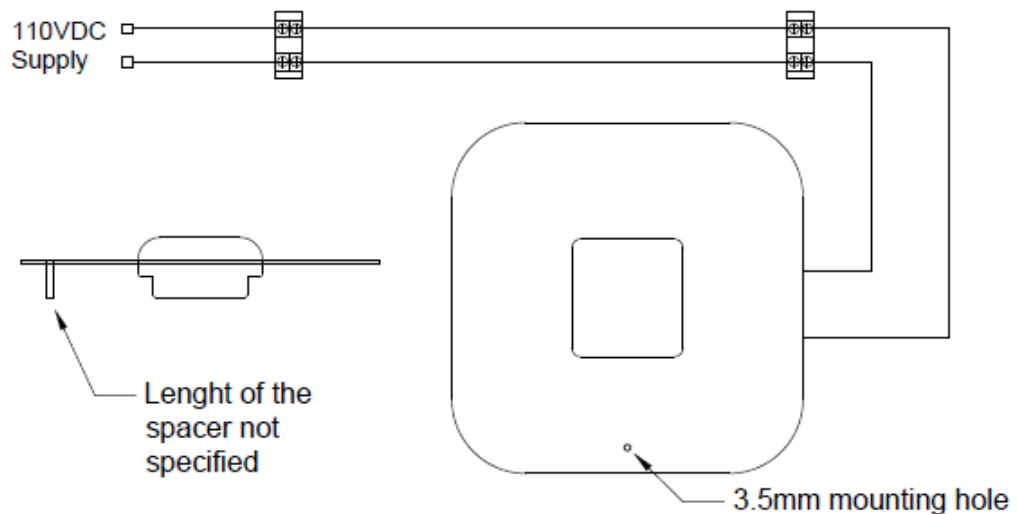

Compliance

The 1084 Series product complies with the following standards and directives:

- › EN61373:2010 Rolling stock equipment. Shock and vibration.
- › EN50121-3-2:2015 Rolling stock equipment. Electromagnetic compatibility.
- › EN50155:2007 Electronic equipment used on rolling stock.
- › EN45545 Fire protection on railway vehicles.
- › EN61347-2-13
with EN61347-1 LED Control Gear
- › EN62031
with EN62471: Photobiological Safety of Lamps
- › ROHS Restriction of Hazardous Substances

This is a draft specification, figures may change due to further testing.

