

Remote Actuator Unit (RAU) with Lockout for DD-Frame (D5)

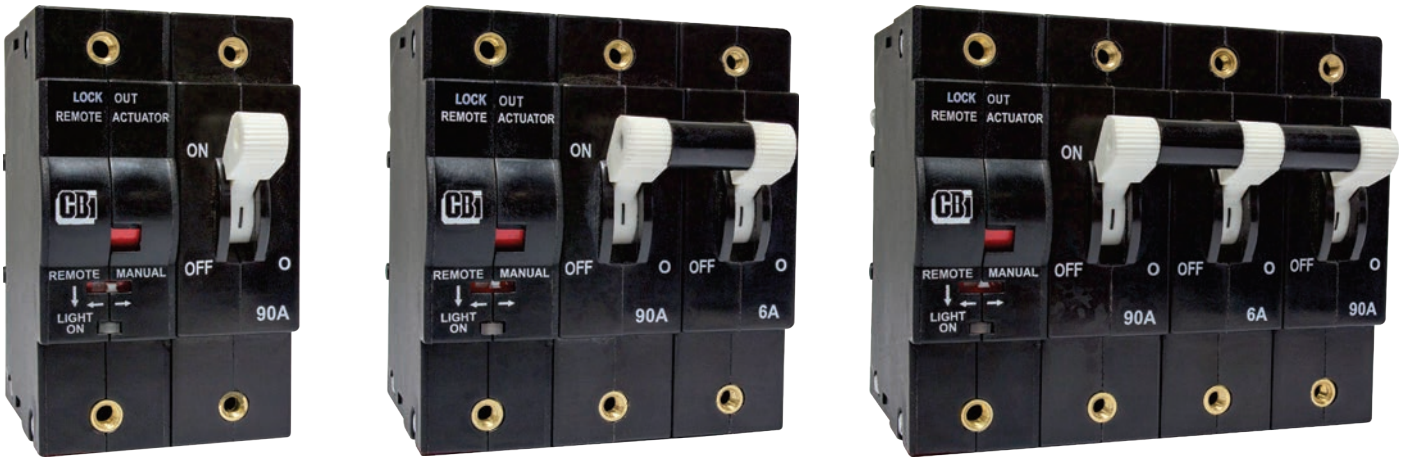

Features

- Remote actuator unit is factory-fitted on the left hand side of the DD-Frame circuit breaker
- The RAU module is designed to function on a wide voltage range: 18 Vdc to 80 Vdc
- **The RAU can be supplied from the main system voltage or a standalone source**
- The DD-Frame circuit breaker operates on the main system voltage, AC or DC
- LED for status indication
- Selectable remote or manual operation
- Provides status of the load side of the circuit breaker
- Remote switching operation requires a high or low signal
- Colour indicator for state of circuit breaker red (ON) or green (OFF)
- Actuation of circuit breaker occurs internally
- Compact size (19 mm, matching DD-frame outline)
- Can be paired with up to a 3 pole DD-frame circuit breaker
- **Device can be locked out to prevent manual operation**

Applications

- Battery management
- Telecommunications
- Railways
- Solar
- System automation
- Switching operations in distant, inconvenient, or unreachable environments

The remote actuation unit (RAU) is a factory-fitted module that enables the automated switching of a DD-Frame circuit breaker. The RAU internally actuates the circuit breaker both ON and OFF. The RAU is mounted on the left hand side of the circuit breaker and can actuate up to three poles. The RAU is available with circuit breakers with a standard toggle handle only. The unit has an LED that provides an indication of the mode of operation (remote or manual) and status. The second is a colour indicator which shows the position of the latching mechanism of the connected circuit breaker - green for OFF and red for ON. The RAU provides the option to set the operation mode between remote or manual. This is selected by a switch situated on the front of the RAU.

Approvals



Remote Actuator Unit (RAU) with Lockout for DD-Frame (D5)

Technical Data

Product Type	RAU		DD Frame
Supply voltage	18 Vdc to 80 Vdc		All values as per DD Frame Circuit Breaker Data Sheet
Actuation signal voltage (For other voltages refer to page 11)	HIGH (ON)	Min. 3.3 Vdc to Max. 60 Vdc	
	LOW (OFF)	Min. 0.0 Vdc to Max. 0.5 Vdc	
Starting current	< 250 mA		
Number of poles that can be actuated	1 to 3 pole DD-Frame - factory fitted		
Ambient operating temperature	-20 °C to +65 °C		
Typical actuation time	OFF state to ON state	2 seconds	
	ON state to OFF state	1 second	
Power consumption	Idle mode	< 250 mW	
	During actuation	< 7.5 W	
Number of operations	In excess of 2000		
Flammability	I3 No flames persistence at 850 °C		
Toxicity	F2 - Smoke index of ≤ 40		
Pollution degree	PD2 - Normally only non-conductive pollution occurs. Temporary conductivity caused by condensation is to be expected.		
Signal Out Resistance to LOAD terminal	330 kΩ ±5% (2 W)		

Product Type	Circuit Breaker	Circuit Breaker	Circuit Breaker	Circuit Breaker
Approvals	UL489	UL1077	IEC60947-2, CE, UKCA	IEC60947-2, UL489 A, CE, UKCA
Number of Poles	RAU + 1, RAU + 2, RAU + 3	RAU + 1, RAU + 2, RAU + 3	RAU + 1, RAU + 2, RAU + 3	RAU + 1, RAU + 2, RAU + 3
Maximum Voltages	120 Vac, 120/240 Vac, 240 Vac, 80 Vdc	277/480 Vac, 80 Vdc	240/415 Vac 80 Vdc	60 Vdc, 80 Vdc
Current Ratings	0.1 - 80 Aac, 0.1 - 200 Adc	0.1 - 100 Aac, 0.1 - 100 Adc	0.1 - 60 Aac, 0.1 - 300 Adc	110 - 250 A, (80 Vdc) 125 A, 250 A & 300 A, (60 Vdc)
Interrupting Capacity	5 kA (AC & DC)	2 kA (AC), 5 kA (DC)	5kA (AC) 10 kA (DC)	5 kA, (60 Vdc)
AIC	10 kA (AC & DC)			10 kA, (80 Vdc)

Verify approvals for specific ratings in accordance with the relevant test certificate

Torque Table

Description	Size	Torque Value
Front Inserts	M3	0.5 - 0.8 Nm
	6 - 32	5 - 7 in/lbf
Rear Studs	M5	2.0 - 2.8 Nm
	10 - 32	18 - 24 in/lbf
	M6	3.5 - 4.0 Nm
	1/4 - 20	30 - 35 in/lbf
Flush Rear Screws	M5	1.7 - 2.3 Nm
	10 - 32	15 - 20 Nm

Aux Switch Specification	
Gold DB3	EN61058 0.1 A @ 250 Vac & 0.1 A @ 80 Vdc and UL1054 0.1 A @ 125/250 Vac & 0.1 A @ 30 Vdc & 0.3 A @ 60 Vdc
Silver DB2	EN61058 10 A @ 250 Vac & 0.1 A @ 80 Vdc and UL1054 10 A @ 125/250 Vac
Silver V4D	EN61058-1 10 A @ 250 Vac

Remote Actuator Unit (RAU) with Lockout for DD-Frame (D5)

Ordering Information

To order a DD-Frame with RAU, select 7 in Group 2 from the DD-Frame circuit breaker ordering code.

Group 1: Frame	Code	Description	Comments					
	D	DD-frame						
Group 2: Type	Code	Description	Comments					
	5	Lockout Remote actuator unit	RAU module attached to DD-frame unit					
Group 3: Mounting	Code	Description	Comments					
	A	Front mount, rectangular aperture, standard (toggle) handle type	Warning: Maximum penetration depth into the product by the mounting screw is 6 mm					
Group 4: Handle Type or Blank for Reduced Handle	Code	Description	Comments					
	A	Standard handle	Toggle					
Group 5: Termination	Code	Description	Comments					
	3X	Plug-in (bullet) terminal (Ø 7.80 mm X 21.5 mm)	125 A max - Ensure the connector has sufficient space so as not to interfere with the terminal bar					
	4X	Flush rear screw terminal, M5 or 10-32	50 A max					
	5X	Double quick connect M3.5 terminal (0.8 mm X 6.35 mm)	50 A max					
	AX	Stud terminals, M5 or 10-32	60 A max					
	DX	Quick connect terminals (0.8 mm x 6.35 mm), top & bottom for mounting version G	30 A max. For rail mounting G in group 3 only					
	LX	Clamp terminal, top & bottom for mounting version G	30 A max. For rail mounting G in group 3 only					
	MX	Stud terminals, M6 or 1/4-20	125 A max					
Group 6: Total No. of Poles	Code	Description	Comments					
	2	2 pole metric	RAU + 1 DD-frame pole					
	3	3 pole metric	RAU + 2 DD-frame pole					
	4	4 pole metric	RAU + 3 DD-frame pole					
	B	2 pole imperial	RAU + 1 DD-frame pole					
	C	3 pole imperial	RAU + 2 DD-frame pole					
	D	4 pole imperial	RAU + 3 DD-frame pole					
Group 7: Rated Voltages and Frequency - Main Circuit	Code	Description	Comments	Description	Comments			
	H	125 Vdc	0.1 A - 60 A Max (Single pole only)	N	80 Vdc			
	J	120 Vac; 240 Vac (Apply to listed single pole products)	50 / 60 Hz	R	120 / 240 Vac; 240 Vac, 240 / 415 Vac (Apply to recognised multipole products)	50 / 60 Hz		
	K	240 Vac; 277 Vac (Apply to recognised single pole products)	50 / 60 Hz	S	120 / 240 Vac; 240 Vac or 240 / 415 Vac (Apply to listed multipole products)	50 / 60 Hz		
	L	AC & DC Application for single pole units (80 Vdc, 240 Vac & 277 Vac)	AC / DC version. With AC and DC curves. (50 / 60 Hz)	V	60 Vdc	No trip alarm, No mid-trip		
	M	AC & DC Application for multipole units (80 Vdc, 240 Vac, 240 / 415 Vac & 277 / 480 Vac)	AC / DC version. With AC and DC curves. (50 / 60 Hz)					
Group 8: Time Delay Characteristics (Pulse Tolerance @ 10 ms)	Code	Description	System	Pulse Tolerance (X In)	Code	Description	System	Pulse Tolerance (X In)
	AD	Long delay 50 / 60 Hz AS & dual rated	AC and DC	8 - 10	CH	Short delay 50 / 60 Hz CS & high inrush	AC	12 - 15
	BD	Medium delay 50 / 60 Hz BS & dual rated	AC and DC	8 - 10	AS	Long delay 50 / 60 Hz	AC or DC	8 - 10
	CD	Short delay 50 / 60 Hz CS & dual rated	AC and DC	6 - 8	BS	Medium delay 50 / 60 Hz	AC or DC	8 - 10
	AE	Long delay 50 / 60 Hz AH & inertia delay	AC	28 - 35	CS	Short delay 50 / 60 Hz	AC or DC	6 - 8
	BE	Medium delay 50 / 60 Hz BH & inertia delay	AC	28 - 35	AW	Long delay 50 / 60 Hz AD & inertia delay	AC and DC	16 - 20
	CE	Short delay 50 / 60 Hz CH & inertia delay	AC	21 - 35	BW	Medium delay 50 / 60 Hz BD & inertia delay	AC and DC	16 - 20
	AI	Long delay 50 / 60 Hz AS & inertia delay	AC or DC	16 - 20	CW	Short delay 50 / 60 Hz CD & inertia delay	AC and DC	12 - 15
	BI	Medium delay 50 / 60 Hz BS & inertia delay	AC or DC	16 - 20	H3	Short delay	DC	6 - 8
	CI	Short delay 50 / 60 Hz CS & inertia delay	AC or DC	12 - 15	OP	Instantaneous trip 50 / 60 Hz	AC or DC	None
	AH	Long delay 50 / 60 Hz AS & high inrush	AC	16 - 20	OX	Switch 50 / 60 Hz	AC and DC	
	BH	Medium delay 50 / 60 Hz BS & high inrush	AC	16 - 20				
Group 9: Main Circuit Current	Code	Description	Comments					
	XXXX	No current, for voltage trip poles						
	100M	0.1 A						
	0100	1 A						
	1000	10 A						
	K250	250 A						
			Specific Ampere rating possible from 0.1 A to 250 A (80 Vdc) 300 A (60 Vdc)					

Continues on page 4

Remote Actuator Unit (RAU) with Lockout for DD-Frame (D5)

Ordering Information

Group 10: Circuit Configuration (circuit breaker's internal construction)	Code	Description	Comments
	AX	Switch	
	BX	Circuit breaker (series trip current sensing)	
	MX	Circuit breaker with trip alarm, but NO MID trip (Reversed function - Latch type)	Handle goes to OFF position when tripped and send a trip alarm
Group 11: Auxiliary and Alarm Switches Types & Options (Refer to Aux switch specification on page 2)	Code	Description	Comments
	X	Not applicable	
	A	Gold tips, equally spaced terminals, 2.75 mm, (0.108") - DB3	Not available on Rail mount
	B	Silver tips, equally spaced terminals, 2.75 mm, (0.108") - DB2	Not available on Rail mount
	C	Silver tips, offset terminals, 4.75 mm, (0.189") - VD4	Not available on Rail mount
Group 12: Voltage and Current Ratings for Dual Control, Shunt and Relay Trip Construction	Code	Description	Comments
	XX	Not applicable	
Group 13: Terminal Options for Dual Control, Shunt and Relay Coils	Code	Description	Comments
	X	Not applicable	
Group 14: RMU Model	Code	Description	Comments
	X	Not applicable	
Group 15: Customer Specification	Code	Description	Comments
	X	Not applicable	
	S	Customer Specific Product	
Group 16: Handle Colour	Code	Description	Comments
	B	Black handle, white marking	
	G	Green handle, white marking	
	W	White handle, black marking	
	R	Red handle, white marking	
	Y	Yellow handle, black marking	
Group 17: Handle Markings	Code	Description	Comments
	D	I – O and ON - OFF	
Group 18: Mounting Orientation for Marking	Code	Description	Comments
	V	Vertical (standard mounting, line at the top)	
Group 19: Front Plate Marking and Test Button	Code	Description	Comments
	A	Standard marking, standard handle	I – O and ON - OFF and ampere rating
Group 20: Inter-phase Barrier and Terminal Cover	Code	Description	Comments
	X	Not applicable	
	1	Terminal cover(s)	
	2	Inter-phase barrier & terminal cover - small	
	3	Inter-phase barrier & terminal cover - large	
4	Inter-phase barrier & terminal cover - Z type		
Group 21: Approvals (Product Normally Approved to)	Code	Description	Comments
	1	CUR, UL recognised UL1077, IEC / EN 60934, CE, UKCA	Normally UL1077 and / or IEC / EN 60934
	2	CUL, UL listed UL489, IEC / EN 60947-2, CE, UKCA	Normally UL489 and / or IEC / EN 60947-2
	3	UL listed (UL489A), IEC / EN 60947-2, CE, UKCA	DC (telecommunication)
Group 22: Safety Marks	Code	Description	Comments
	X	Not applicable	

Verify approvals for specific ratings in accordance with the relevant test certificate

Remote Actuator Unit (RAU) with Lockout for DD-Frame (D5)

Connection Diagrams

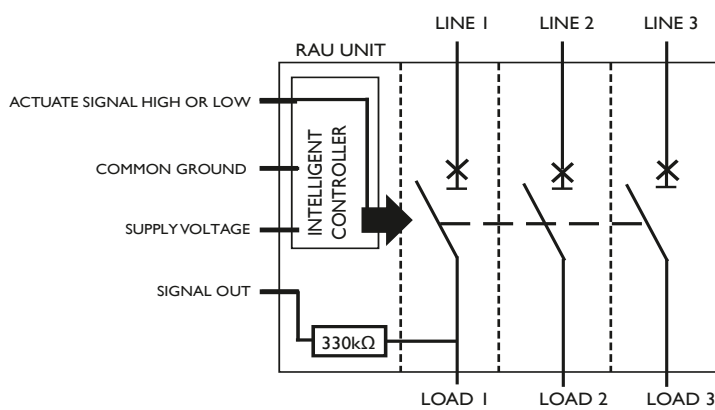
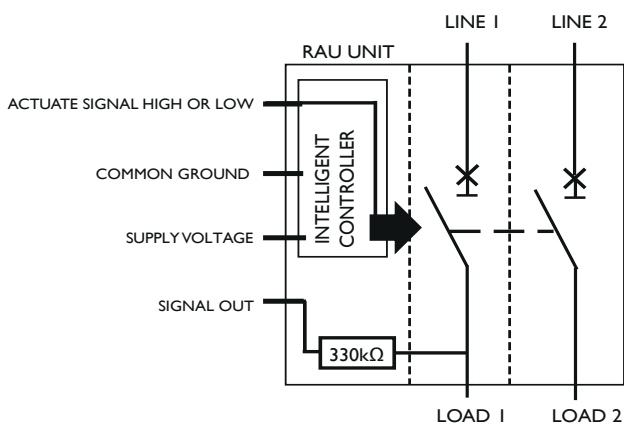
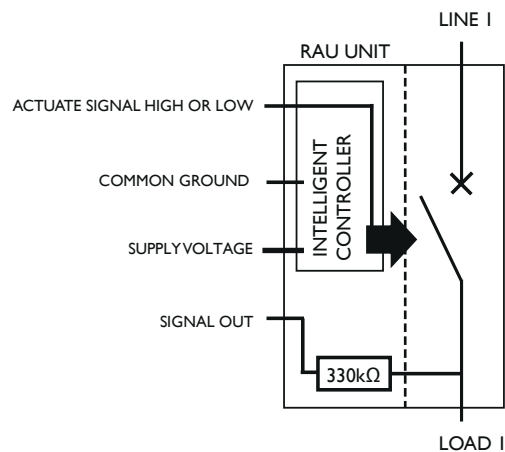
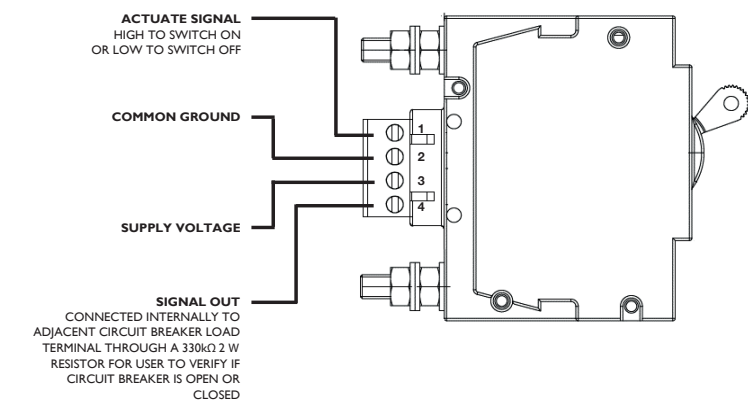

Note: Signal out only provides status indication of the adjacent pole through a 330 kΩ resistor.

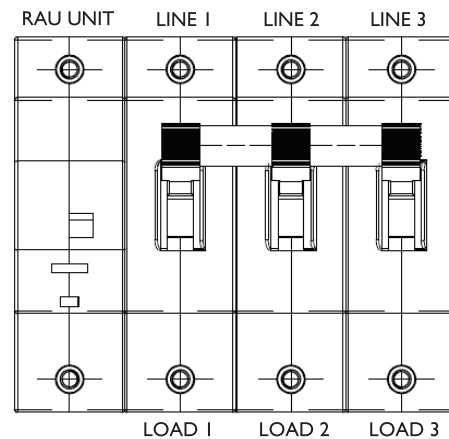
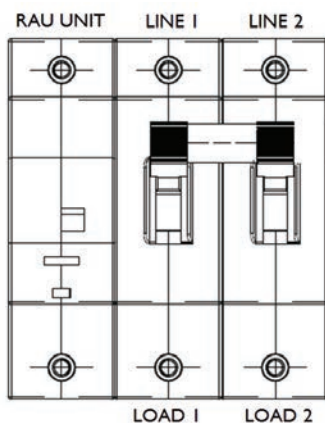
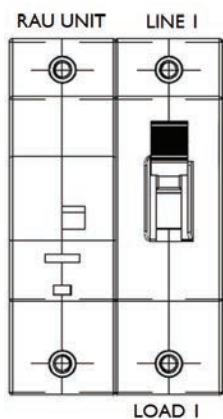

Remote Actuator Unit (RAU) with Lockout for DD-Frame (D5)

Plug compatible with DEGSON 2EDGKF-5.08-04P -14 and a PHOENIX CONTACT plug 1780002.

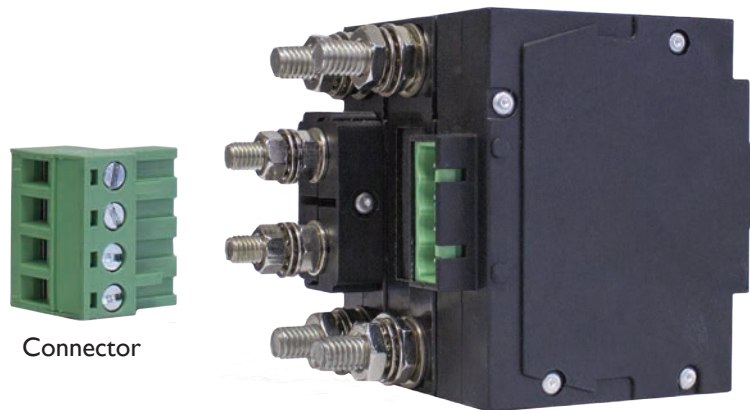

The RAU front switch has two positions, namely "Remote" or "Manual". Refer to table 1 on page 7 for more details.

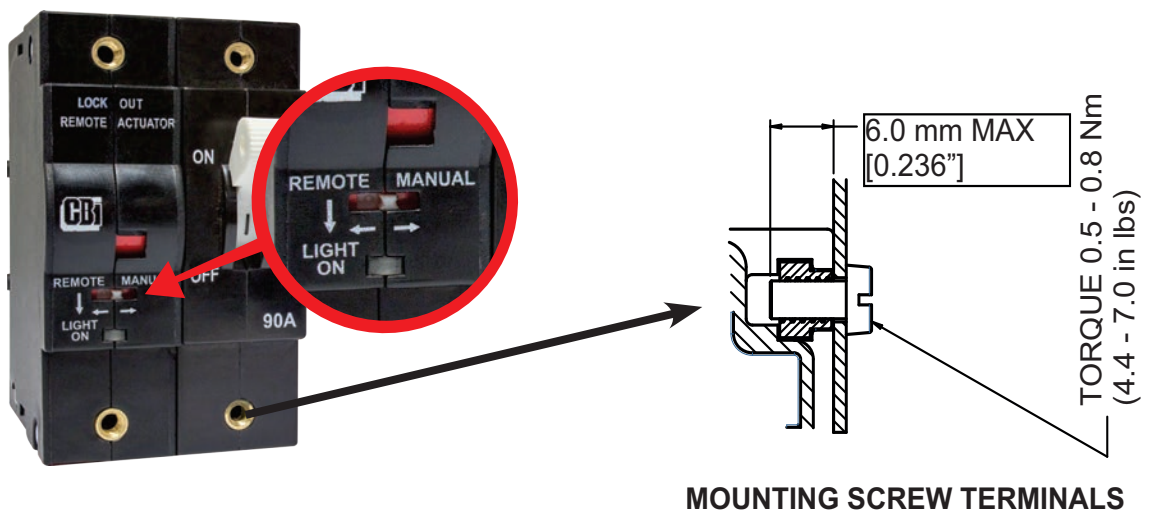

Installation Instructions

1. Before connecting the RAU to power, the circuit breaker must be in the OFF position and the RAU front switch must be in the REMOTE position.
2. Isolate the power to the circuit breakers.
3. Connect the circuit breakers as required and connect the necessary wiring for the RAU as shown in the connection diagram (page 5).
4. With the circuit breaker in the OFF position, activate the supply to the circuit breakers and the RAU. The LED on the RAU will flash 3 times during its initialisation process. The LED will then illuminate, indicating that the RAU is now ready for operation.

Remote Actuator Unit (RAU) with Lockout for DD-Frame (D5)

Remote Operation

Set the front switch to REMOTE to enable remote operation. The LED will be illuminated

1. Switching the circuit breaker ON using the RAU:

- Set the actuate signal HIGH. This will switch the circuit breaker ON remotely. While the actuate signal remains in the HIGH state, the circuit breaker can be operated manually like a conventional circuit breaker.

2. Switching the circuit breaker OFF using the RAU:

- Set the actuate signal to LOW. This will switch the circuit breaker OFF. While the actuate signal is LOW, the circuit breaker will be internally held in the tripped position and cannot be switched ON manually.

3. If the circuit breaker trips, then to remotely switch the breaker ON again, the Actuate Signal must be set to LOW and then a HIGH signal must be reapplied.

NOTE:

- DO NOT** move or block the circuit breaker handles while the RAU is actuating remotely.
- DO NOT** change the state of the actuate signal or RAU front switch rapidly, or while the circuit breaker is in motion, allow at least a 3 seconds waiting period before changing the state.

Manual Operation

Set the front switch to MANUAL to disable remote operation. Manual mode prevents the breaker from automatically turning on.

Changes to the remote signal enables or disables the lock-out feature:

A breaker that was manually turned on, will trip to lock out if the remote signal goes LOW. The LED blinks to indicate this state.

If subsequently the actuation signal goes HIGH, manual operation becomes possible again.

The breaker will not turn on automatically while manual - only unlock internally.

The feature ensures that lock-out can always be enforced when required.

The RAU Operation

The RAU will trip the circuit when the RAU front switch is toggled. RAU operation can be described in terms of changing states based on the remote signal or the front switch. The various states are as follows:

Table 1: RAU front switch and operation states

Initial State					Change		Response	
State	Signal	Switch	LED	Manually Operable	Signal	Switch	RAU Action	New State
A	HIGH	REMOTE	ON	Yes	to LOW		turns off and block manual operation	C
						to MANUAL	turns off to enter manual	B
B	HIGH	MANUAL	OFF	Yes	to LOW		turns off and block manual operation	D
						to REMOTE	turns off, then turns on to enter remote	A
C	LOW	REMOTE	ON	No	to HIGH		turns on	A
						to MANUAL	remains blocked in off position	D
D	LOW	MANUAL	Blink	No	to HIGH		unblock manual operation	B
						to REMOTE	enter remote mode in off position	C

Remote Actuator Unit (RAU) with Lockout for DD-Frame (D5)

LED Status Indication

LED State	Indication
Flash 3 times	Initialisation
Flash 3 times every 4 seconds	Fault state
ON	Remote actuation mode
OFF	Manual operation mode
Blinking	User will not be able to switch breaker on manually
2 Short flash & 1 long flash	Initialisation fault

Application Notes:

RAU powered from Negative DC Bus

The DD-frame RAU requires a positive supply voltage between 18 Vdc and 80 Vdc to operate, however, systems may only have a negative voltage supply available. The RAU is able to accommodate such environments. Figure 1 shows an example of an RAU in a telecommunications application which only has a -48 Vdc bus voltage available. Resistor R is required if the potential difference between the Actuate Signal pin and the Common pin is greater than 60 Vdc.

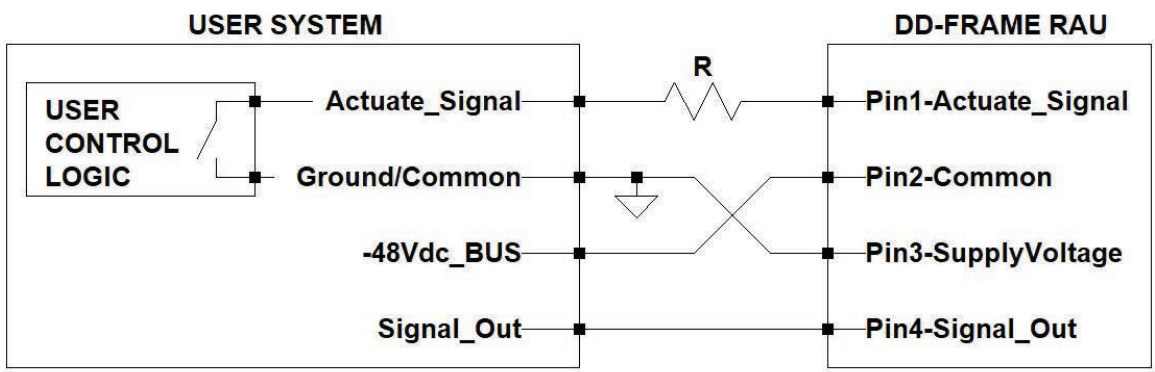

Figure 1: Wiring diagram example for DD-Frame RAU powered from negative supply bus in a -48 Vdc telecommunications application

Remote Actuator Unit (RAU) with Lockout for DD-Frame (D5)

Using the Signal Out

Signal out can have many functions and is not just an auxiliary contact to indicate the open / closed state of the circuit breaker. The signal out function will depend on its specific application. This application note will convey the function of signal out for various applications under resistive loads only.

The signal out contact is connected only to the adjacent pole LOAD side and is isolated from the control.

Note that the signal out will vary depending on the type of load and will need to be taken into consideration when designing the RAU into a system.

Table 2: Wiring Configuration

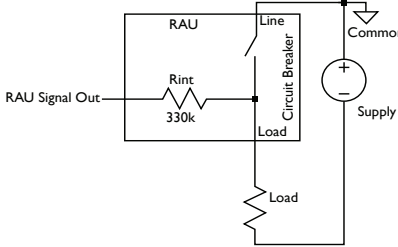
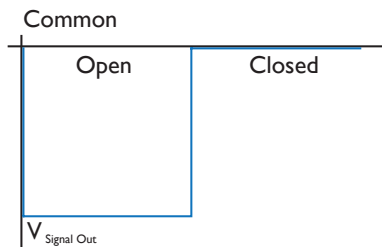
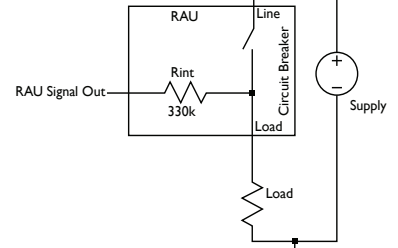
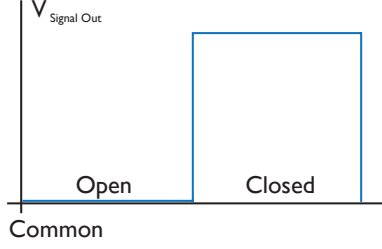
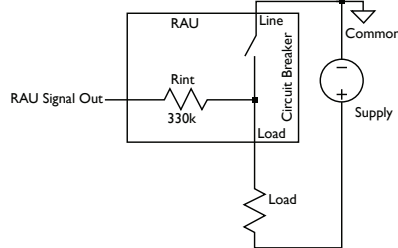
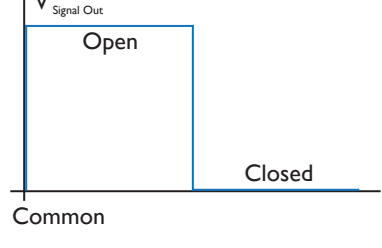
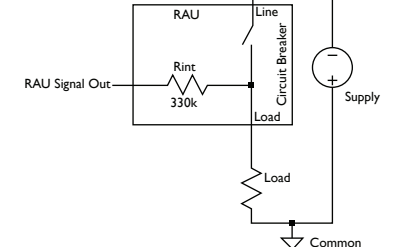
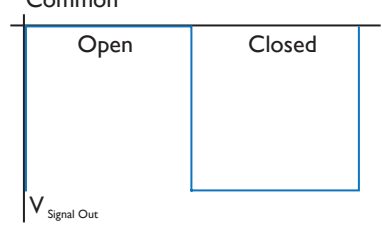
Wiring Configuration	Signal Out with reference to common when circuit breaker is open or closed	Purpose of Signal out
		Monitor status of circuit breaker
		Monitor status of circuit breaker
		Monitor status of circuit breaker
		Monitor status of circuit breaker

Remote Actuator Unit (RAU) with Lockout for DD-Frame (D5)

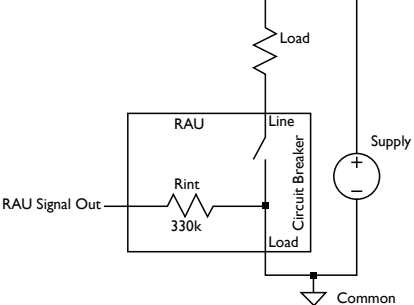
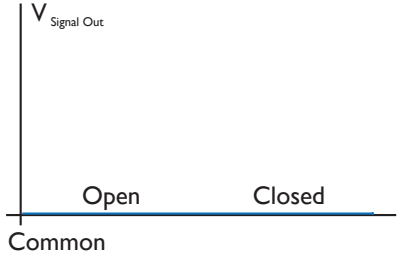
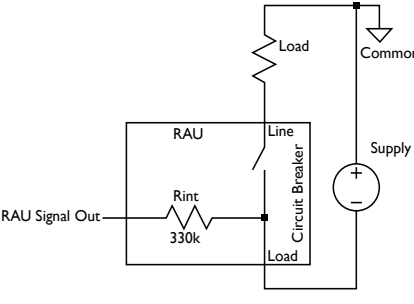
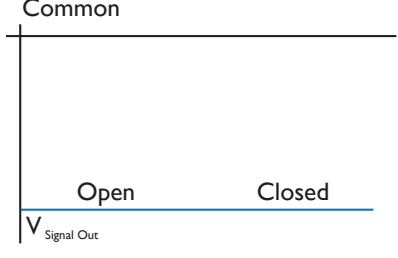
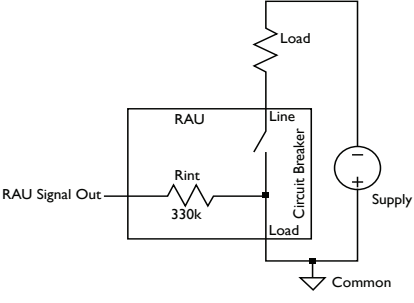
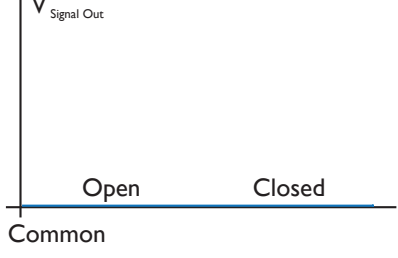
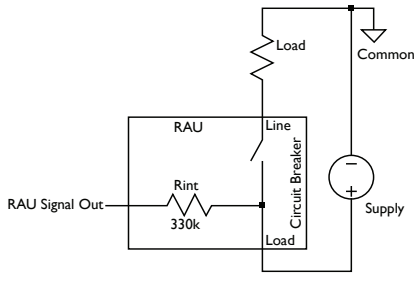
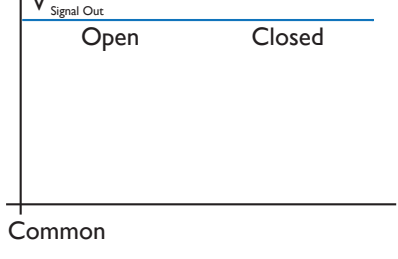
Wiring Configuration	Signal Out with reference to RAU Common	Purpose of Signal out
		Common potential monitoring
		Monitor Supply
		Common potential monitoring
		Monitor supply

Remote Actuator Unit (RAU) with Lockout for DD-Frame (D5)

Actuation Signal Voltage Greater than 60 Vdc

The maximum actuation signal voltage that can be applied to the DD-Frame RAU is 60 Vdc. If the application is such that the actuation signal voltage will be larger than 60 Vdc, then an external resistor must be added in series as indicated in figure 2.

The value of the resistor can be designed for using the following equation:

$$R = \left(\frac{V_{\text{supply}} - 60}{0.001} \right) \text{ with deviation of } \pm 20\%$$

For example, if the actuation signal voltage will be 72 Vdc, then a 12 kΩ resistor must be added in series. See table 3.

External resistor to add in series for actuation signal voltage above

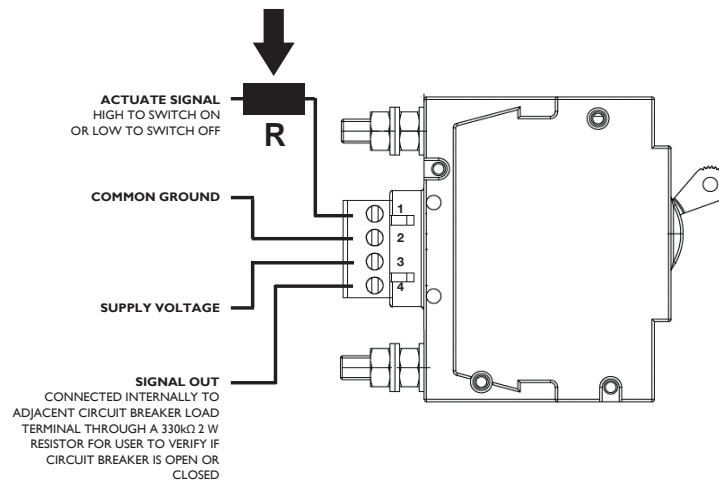

Figure 2: Side view of DD-Frame RAU indicating how to add resistor in series for actuation signal voltages above 60 Vdc

Table 3: Actuation signal voltages and corresponding resistor values to be added in series

Actuation Voltages in Volts dc	External resistor to add in series with actuate terminal (E12 series)
72	12 kΩ
80	22 kΩ

Alternatively, a voltage divider may be implemented to create a signal voltage between 5 Vdc and 60 Vdc. The minimum current required by the actuation signal input is 5 mA.

Remote Actuator Unit (RAU) with Lockout for DD-Frame (D5)

Dimensional Drawings

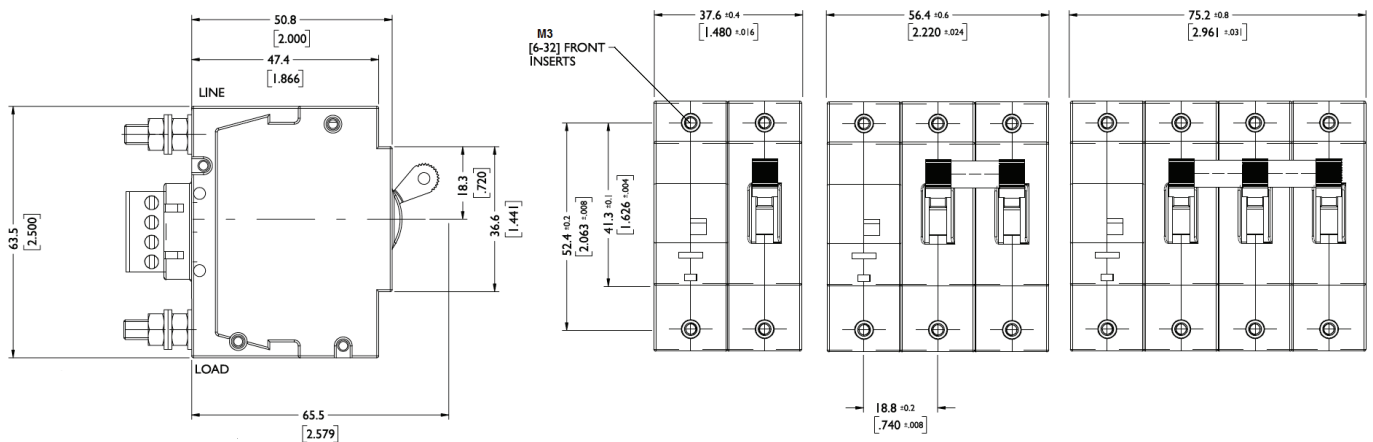

Please review our Customer Terms and Conditions on www.cbi-lowvoltage.co.za

© CBI (Pty) Ltd. All Rights Reserved.

All rights reserved. Unless otherwise indicated, all materials on these pages are copyrighted by CBI (Pty) Ltd. No part of these pages, either text or image may be used for any purpose other than personal use. Therefore, reproduction, modification, storage in a retrieval system or retransmission, in any form or by any means, electronic, mechanical or otherwise, for reasons other than personal use, is strictly prohibited without prior written permission. CBI (Pty) Ltd reserves the right to alter any details of this document without notice and while every effort is made to ensure the accuracy of the content, no warranty is given as to the accuracy of this document and no responsibility will be accepted for error or misinterpretation and any resulting loss.

AUSTRALIA

CBI-electric: Australia
 27 Wedgewood Rd, Hallam
 Victoria 3803 Australia
 Tel: +61 3 8752 9300
 Fax: +61 3 9796 5407
 Email: sales@cbi-electric.com.au
 Website: www.cbi-electric.com.au

SOUTH AFRICA

CBI-electric: low voltage
 Tripswitch Drive Elandsfontein
 Gauteng South Africa
 Tel: +27 11 928 2000
 Fax: +27 11 392 2354
 Email: cbi@cbi-electric.com
internationalsales@cbi-electric.com
 Website: www.cbi-lowvoltage.com

USA

CBI-electric: North America
 35 E. Uwchlan Ave Suite 328
 Exton PA 19341 USA
 Tel: +1 610 524 9949
 Fax: +1 610 524 9945
 E-mail: info@cbibreakers.com
 Website: www.cbibreakers.com